

# CARRIER 19 XR CENTRIFUGAL CHILLER HEAD PRESSURE VALVE CONTROL WIRING

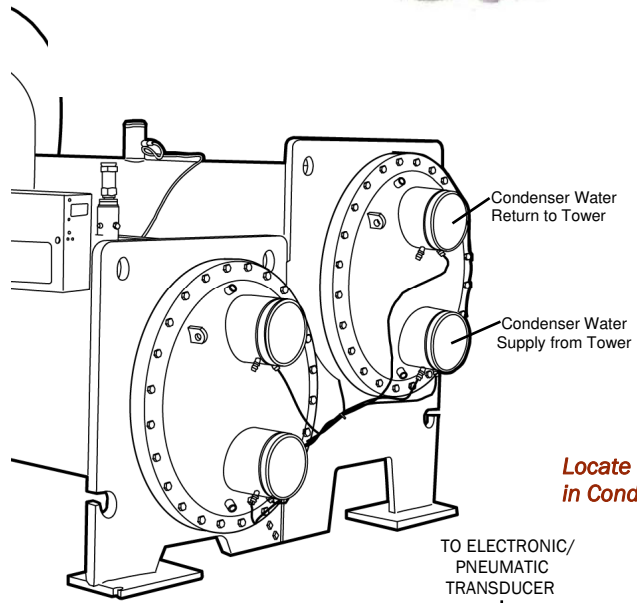

**Locate Chiller Head Press Valve in Condenser Water Return Line**

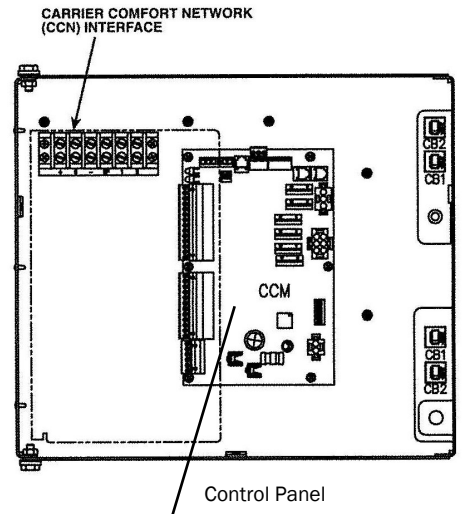
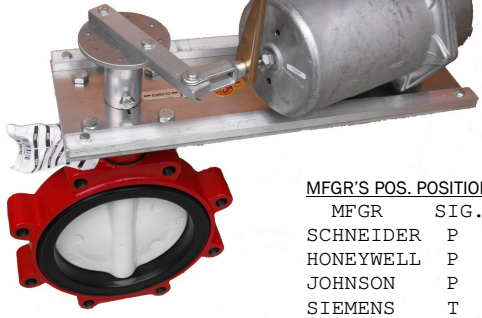
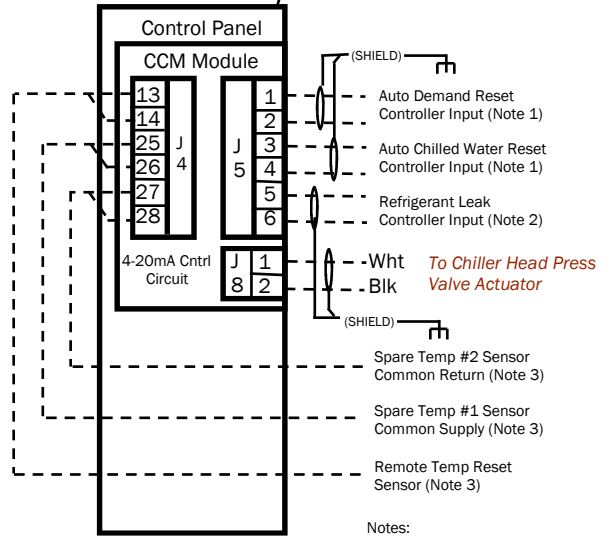

TO ELECTRONIC/PNEUMATIC TRANSDUCER

| MFGR'S POS. POSITIONER CONNECTIONS |      |        |          |
|------------------------------------|------|--------|----------|
| MFGR                               | SIG. | -MAIN- | ACTUATOR |
| SCHNEIDER                          | P    | M      | B        |
| HONEYWELL                          | P    | M      | B        |
| JOHNSON                            | P    | S      | O        |
| SIEMENS                            | T    | S      | M        |

**PNEUMATIC CONDENSOR WATER VALVE**



**WESLY VALVE CO.**

MFGRS OF AUTOMATED BUTTERFLY VALVES  
3229 North L Street  
Pensacola, FL 32505  
PHN: (404) 351-8744 FAX: (404) 351-9340  
[www.weslyvalve.com](http://www.weslyvalve.com)

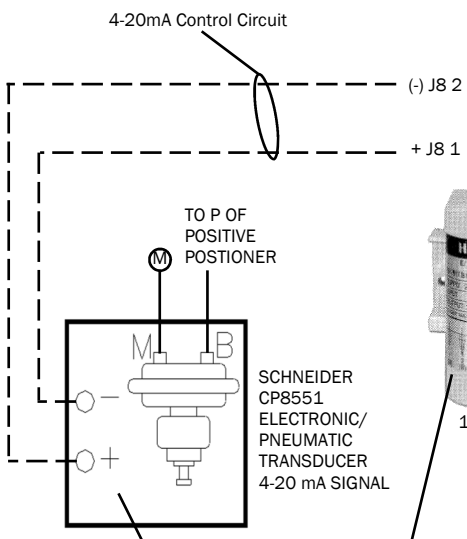

Use for 4-20 mA Signal

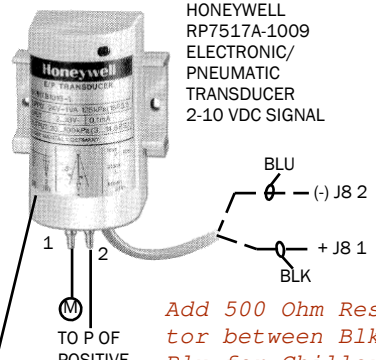

2-10 VDC Signal

Add 500 Ohm Resistor between Blk & Blu for Chiller 4-20 mA Signal

# CARRIER 23 XRV SCREW CHILLER HEAD PRESSURE VALVE CONTROL WIRING

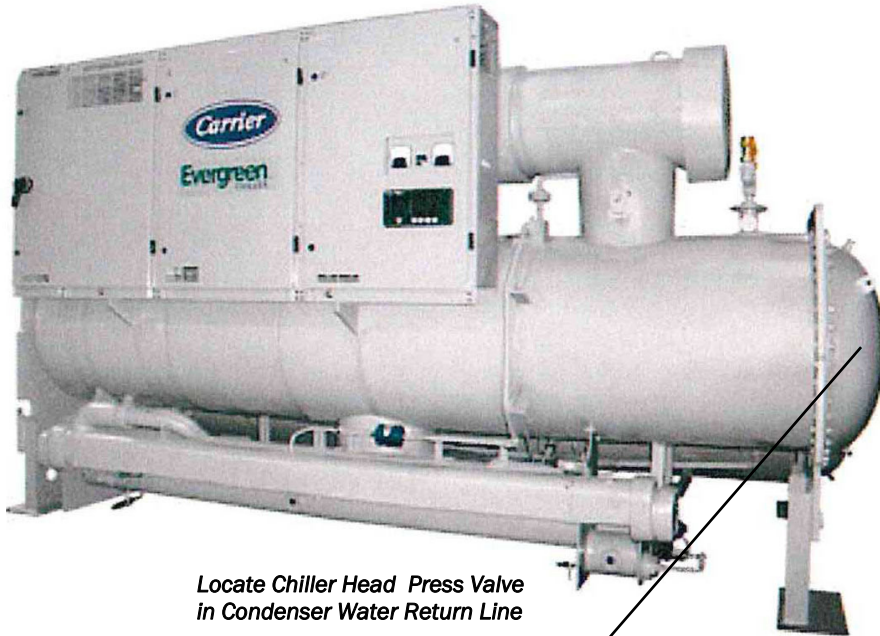

Locate Chiller Head Press Valve  
in Condenser Water Return Line

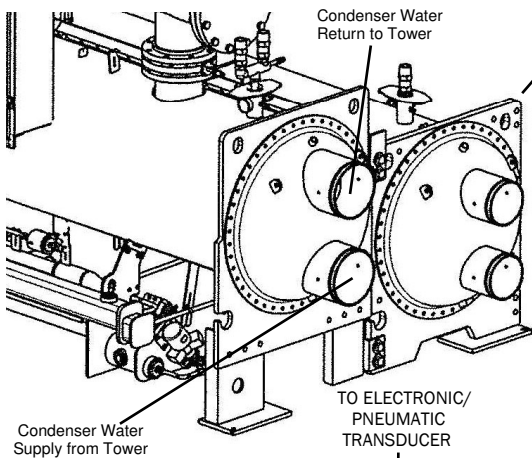

CARRIER 19XR CENTRIFUGAL  
CHILLER CCM MODULE AND  
HEAD PRESSURE VALVE  
CONTROL WIRING IS IDENTICAL

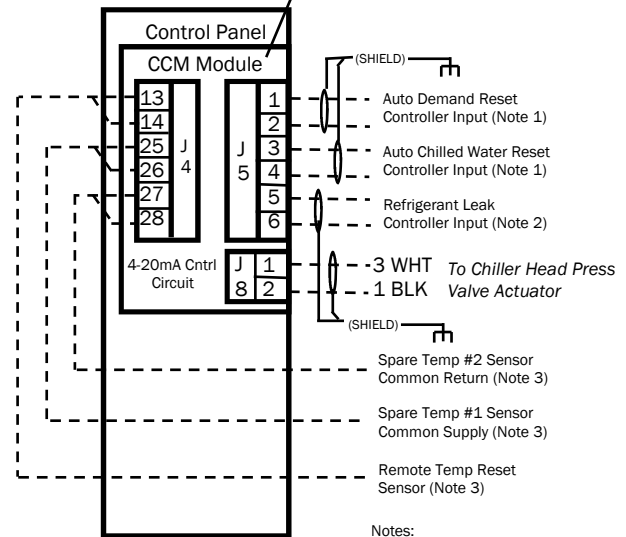
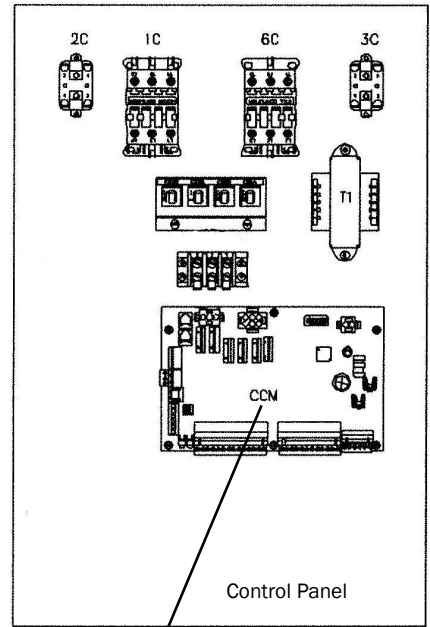

- Notes:
1. Requires a controller with a non grounded 4-20 mA or 1-5 Vdc signal. Not by Carrier
  2. Requires a controller with a non grounded 4-20 mA or 1-5 Vdc signal Not by Carrier
  3. Requires a sensor package option by Carrier

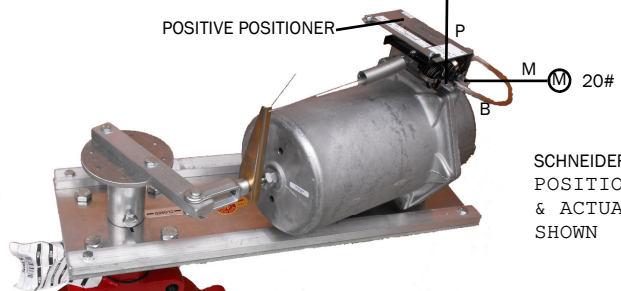

**MFGR'S POS. POSITIONER CONNECTIONS**

| MFGR      | SIG. | —MAIN— | ACTUATOR |
|-----------|------|--------|----------|
| SCHNEIDER | P    | M      | B        |
| HONEYWELL | P    | M      | B        |
| JOHNSON   | P    | S      | O        |
| SIEMENS   | T    | S      | M        |

## PNEUMATIC CONDENSOR WATER VALVE



**WESLEY VALVE CO.**  
MFGRS OF AUTOMATED BUTTERFLY VALVES  
3229 North L Street  
Pensacola, FL 32505  
PHN: (404) 351-8744 FAX: (404) 351-9340  
[www.wesleyvalve.com](http://www.wesleyvalve.com)

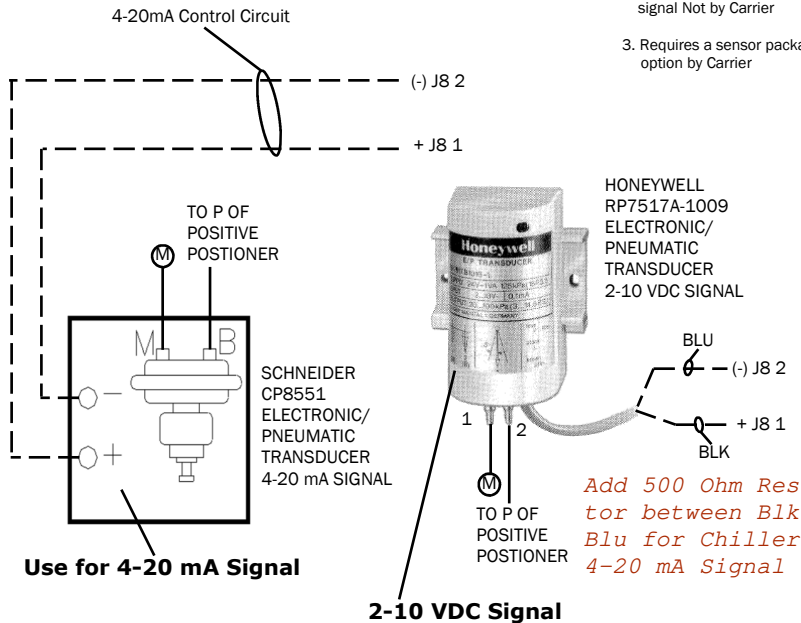

Add 500 Ohm Resistor between Blk & Blu for Chiller 4-20 mA Signal

2-10 VDC Signal



# CARRIER 30 HXC SCREW CHILLER UNITS HEAD PRESSURE VALVE CONTROL WIRING

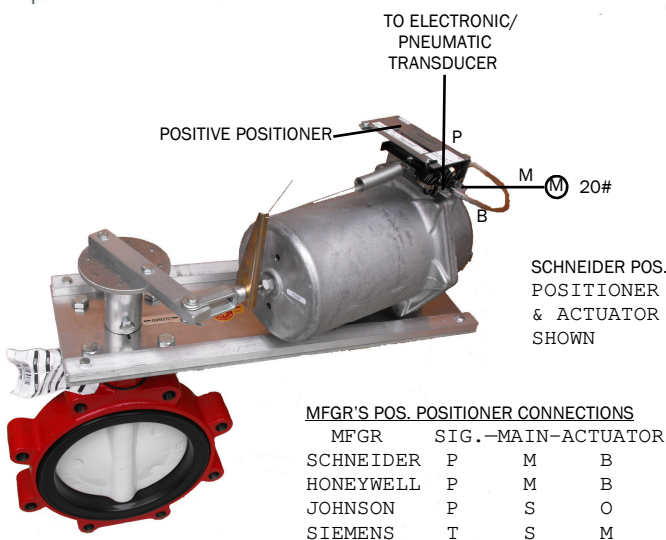
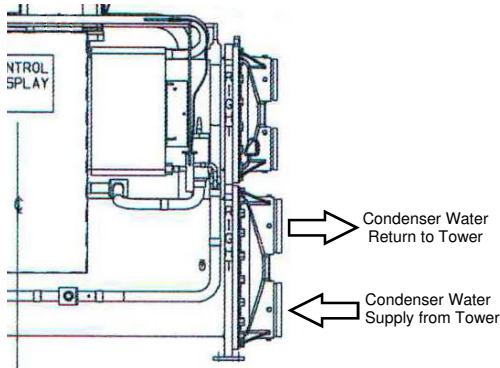

## PNEUMATIC CONDENSOR WATER VALVE

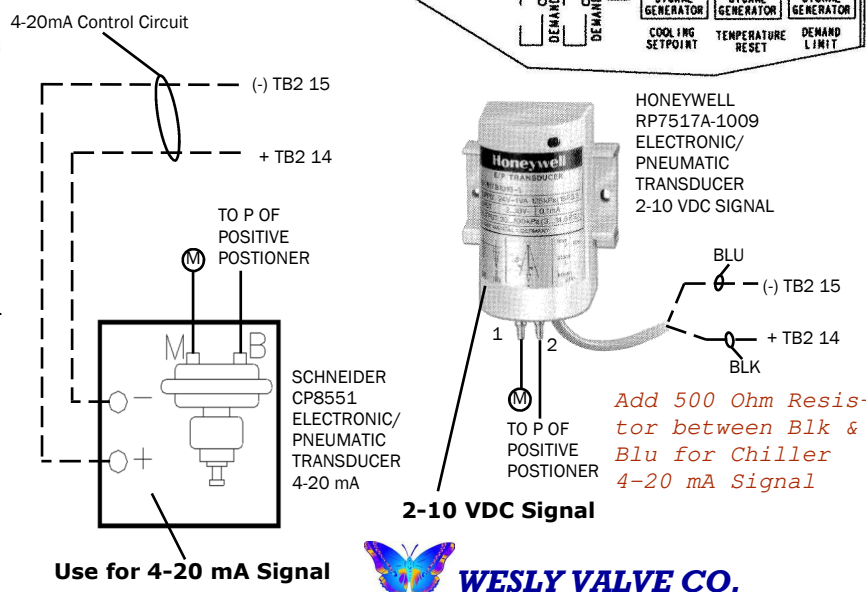
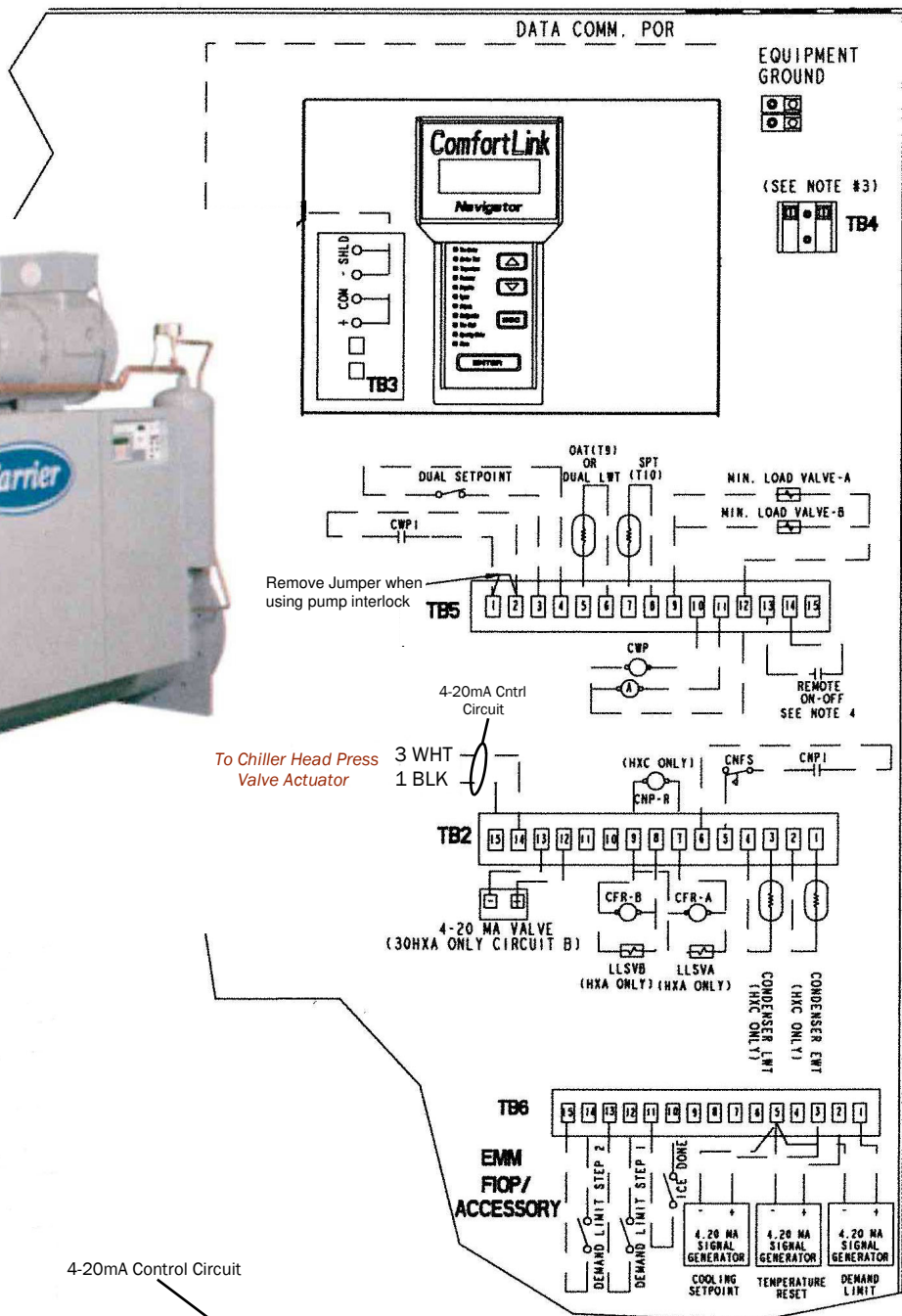

**WESLEY VALVE CO.**

MFGRS OF AUTOMATED BUTTERFLY VALVES  
3229 North L Street  
Pensacola, FL 32505  
PHN: (404) 351-8744 FAX: (404) 351-9340  
[www.wesleyvalve.com](http://www.wesleyvalve.com)